

FastPulse Technology, Inc.

LASERMETRICS® Division

220 MIDLAND AVENUE
SADDLE BROOK, NEW JERSEY 07663
TEL (973)-478-5757
FAX (973)-478-6115
Web Site: www.lasermetrics.com

MODEL 5046ER-VC

HIGH SPEED

ELECTRO-OPTIC GATING SYSTEMS

(With 5046E or 5046EM Optical Head Assemblies)

RoHS2



SERIAL NUMBER: 5698-1

**WHEN CALLING OR CORRESPONDING ABOUT THIS INSTRUMENT,
ALWAYS MENTION THE MODEL & SERIAL NUMBERS**

NOTE: The “VC” option is now standard on all 5046ER Systems. It is an upgrade provided at no additional cost. This feature allows control of the output HV Pulse Amplitude by an externally applied low frequency or variable DC low voltage supplied by the end user.

FastPulse Technology, Inc.

LASERMETRICS[®] Division

CONTENTS

	Page No.
CE Statement .& RoHS	3
Component Model Numbers	4
5046E/5046ER System Specifications & Data	5-7
High Voltage Warning	8
Operational & Control Functions - Labels	9
Front Panel - 5046ER Rack Mounted PS/TG.(Fig. 2)	10
5046E & 5046EM Optical Head Assembly Enclosure	11
1.0 General Description	12
1.1 System Operational Description	13
Figure 5: Timing Diagrams	14
2.0 Optical System - General Description	15
2.1 Optical System Alignment	15
3.0 System Connections	16
3.1 Input Functions	16
3.2 IN / OUT Delay Functions	17
3.3 Pulse Width Generator	17
3.4 Unsynchronized CW Mode Operation	17
4.0 System Operation	18
4.01 — 4.07 Set-Up Procedures	18
Figure 6: Connections for CW Mode-Locked Lasers .	19
Figure 7: Connections for Pulse Pumped Q-switched, Q-switched/Mode-locked & CW Lasers ...	20
5.0 Direct Triggering of HV Output Pulse Modules ...	21
Figure 8: Connections for Direct Triggering	21
6.0 EMI Considerations	22
Warranty	23
Addenda (If any)	24
Attachments: Technical Notes & Guides	

FastPulse Technology, Inc.

LASERMETRICS® Division

220 MIDLAND AVENUE
SADDLE BROOK, N.J. 07663
TEL: 973-478-5757
FAX: 973-478-6115



RoHS2

FastPulse Technology, Inc. certifies that all of its electronic, mechanical, electro-optic and optical products comply with EU Directives 2002/96/EG and 2011/65/EU on the restriction of use of certain hazardous substances (RoHS). This instrument is RoHS2 Compliant and meets the restrictions of related EU Directives for hazardous materials: lead, cadmium, mercury, hexavalent chromium, PBB and PBDE; and conforms to the protection requirements of EMC Directive 89/336/EEC, specifically, EN 55011 Radiated and Conductive Emissions, EN 50082-1 Immunity (IEC 801-2, -3, -4) and safety requirements of EN 60601-2-22 (IEC 601-2-22:1995-11).

It is essential that the instrument be correctly connected, that the AC mains ground have a low impedance and that following precautions are observed:

1. Replacement Cables: Interconnecting coaxial cables must be matched to the impedance of the connectors used on the instrument, its input signal source and where possible, the output circuit load . Thus, 50 Ω BNC cable connectors must be attached to 50 Ω cable (RG58A/U OR RG55/U) and 75 Ω MHV cable connectors to 75 Ω cable (RG59/U). Impedance mismatches will cause ringing and radiated emissions. To reduce residual emissions due to impedance mismatch, aluminum foil may be wrapped around the cables or the cables may be enclosed in flexible braided copper tubing which is made for this purpose. In either case, the shielding must be well grounded.
2. Pockels cells which may be supplied as accessories to this instrument are passive components which are intended to be operated in the end-user's shielded enclosure. Failure to properly enclose the cell may result in electrically radiated noise.
3. As supplied, the Pockels cell light modulator and HV Pulse Modules are enclosed in a EMI shielded enclosure. This metal enclosure must be connected electrically to house ground and to the ground connector located on the rear of the Power Supply chassis. Because the modulator enclosure must have apertures to permit passage of the laser beam, these openings may be a source of low level RFI/EMI. If sensitive detectors or instruments are located in the immediate vicinity of the enclosure apertures, it may be necessary to provide additional shielding around the apertures in the form of a second grounded metal enclosure or a small cardboard carton covered with aluminum foil. The foil is grounded and two apertures are cut into the foil and cardboard. If the distance between the apertures in the modulator enclosures or cardboard box is 1 to 2 inches (25 to 50 mm) the residual radiation, if any, will be significantly attenuated
4. This instrument generates output voltages which can be hazardous. It is important to read and understand the operations manual provided with the instrument prior to connecting and applying AC line power. All cables must be connected to their mating connectors before application of AC line power and turn-on of the power switch.
5. Before connecting the AC power line cord to the chassis connector, always check that the line voltage selector switch or power connection selector is set in the appropriate line voltage position. Connecting the unit to 240 Volts with the selector set to 110 or 115 Volt position will result in damage to the internal circuits. Refer To Addendum at rear of this manual for more information about settings.

5046ER SYSTEM COMPONENTS - MODEL NUMBERS

SYSTEM SERIAL NO. 5698-1

POWER SUPPLY/TIMING GENERATOR (PS/TG), MODEL ■ 5046ER-VC

OPTICAL HEAD ASSEMBLY (OHA)

■ 5046E (OHA) - 2.6" OPTICAL CENTER LINE HEIGHT

□ 5046EM (OHA) - 2.0" OPTICAL CENTER LINE HEIGHT

E-O MODULATOR, MODEL: Q1059PSG-1064

POLARIZER(S), MODEL: N/A

GIMBAL ASSEMBLY, MODEL □ MG-145, ■ MGC-145, □ PCH-1

Notes:

1. For all 5046 Optical Head Assemblies ;the heavy aluminum base of the OHA is intended to be mounted on a thermally conductive surface to minimize temperature rise within the OHA. Two slotted bolt holes are provided to insure a good clamping action to the heat sinking surface.
2. The 5046EM Optical Head Assembly has an optical center line height of 2.0 inches. This is attained by use of a Newport Model PCH-1 Gimbal device which does not have external micrometer adjusting handles. After removing the OHA cover, Pitch and Azimuth adjustments on the PCH-1 are made by means of a hex key wrench (Allen Head wrench). Position of the hex head screws can be locked and unlocked by means of the opposed screws with slotted heads.
3. Dimensions for the 5046E and 5046EM OHA housings are shown in Figure 3.
4. **5046ER-VC, Serial Number 5698-1 – High Voltage Control: +0.5 Volt DC in for 1 kV DC out - up to +5 Volts DC for 10 kV DC out.**

MODEL 5046ER-VC POWER SUPPLY / TIMING GENERATORS

Specifications and Data Sheet

Serial No. 5698-1

AC LINE

*Voltage, Frequency (Set For) 100-117 V, 230-240 V, 50/60 Hz (NOMINAL)
 100 Volts, 60 Hz
 Refer to Addenda rear of manual

Power 35 Watts

Fuse 2 Amp BUSS -- MDL-2A

*** TO CHANGE LINE VOLTAGE SETTING:** Before applying AC Line Power, check to make sure the voltage selector switch on the rear of the chassis is set for the appropriate line voltage. For the 5046E, an external slide switch is located at the rear of the chassis. For the Model 5046ER, refer to the Addendum at the rear of this manual. CAUTION - operating the unit at 230-240 Volts with the switch in the 115 Volts position will result in damaged components. Change Line Voltage setting only when the AC line cord is detached from the mating chassis connector.

FUNCTION	SENSITIVITY POSITION	VOLTAGE @ 50 Ohms	
		E_{in}	E_{mon}
Photo or Negative	Max.	-55 mV	≥ 3 mV
	Min.	-1.1 V	≥ 180 mV
Positive Trigger	Max.	55 mV	≥ 3.7 mV
	Min.	1.0 V	≥ 180 mV

Figure 1. TRIGGER INPUT VOLTAGES - Nominal values

Test conditions: Trigger applied to either input:

- 1) The input polarity is as indicated.
- 2) FWHM pulse width is ≥ 1 ns and ≤ 1 μ s.
- 3) The indicated voltage levels are typical thresholds that achieve a stable output pulse.
- 4) The maximum positive or negative input is 5 volts.
- 5) Input trigger pulse widths between 10 ns and 1 μ s are acceptable

5046ER SYSTEM SPECIFICATIONS, Nominal Values - Continued

Power Supply / Timing Generator (5046ER PS/TG) Cabinet)

Input/Output Delay Range	
Delay "ON" side	100 ns to 1.2 μ s
Delay "OFF" side	100 ns to 1.2 μ s
Pulse Width (PW) Range	0 to 1.2 μ s
PW Monitor Output, into 50 Ω	~1.2 Volts
High Voltage Range, DC	0 to 10 kV DC Max.
Useful HV Operating Range	1 kV DC to 10 kV DC
VC IN HV Control Range	+0.5 Volt to +5 Volts DC for 1kV to 10 kVDC Output
Bias Voltage	~700 VDC, typical (factory set, non-adjustable)
Trigger Output(s), into 50 Ω	
On Trigger	5 V
Off Trigger	5 V
EXT GATE Input (Command Trigger) (marked CW in older units)	1.5 V (10 ns min., 1 μ s max.)

HV Output Pulse Modules (Inside Optical Head Assembly)

Output Pulse Width Range (Optical)	≈6 ns to 1.2 μ s
In/Out Delay, (ON or OFF)	≈45 ns
Rise Time (ON) (Optical 10%-90%)	<2.5 ns
Rise Time (OFF) (Optical 10%-90%)	<2.5 ns
Extraction Rate	Single Shot to 5 kHz

NOTE: The "VC" option is now standard on all 5046ER Systems. It is provided at no additional cost. This feature allows control of the output HV Pulse Amplitude by an externally applied low frequency or variable DC low voltage supplied by the end user.

Serial No. 5698-1

FastPulse Technology, Inc.

LASERMETRICS® Division

220 Midland Avenue
Saddle Brook, NJ 07663
TEL: 973-478-5757
FAX: 973-478-6115
Web Site: www.fastpulse.com

POCKELS CELL OPERATIONAL CHARACTERISTICS

Model Number: Q1059PSG-1064 SERIAL No. 5698-1

Crystal Material: (>98.5 D₂) KD*P

Crystal Coatings: Sol Gel AR 1064 nm

Window Material: Fused Silica

Window Coatings: AR/AR 1064 nm

Linear Aperture: 10 mm Diameter

Index Matching Fluid: N/A

Polarizer: N/A

Analyzer: N/A

Intrinsic Contrast Ratio @ 633 nm (Crossed to Open Polarizers): 2300:1

Voltage Contrast Ratio @ 633 nm: 2250:1, from 0 to ~3.8 kVDC

Half Wave Retardation Voltage @ 633 nm : ~3.8 kVDC

Calculated Half Wave Retardation Voltage: ~6.4 kV DC @1064 nm

Capacitance: ~5.2 pf

Tested By: Val Date: 15July 2016

**When requesting information on this unit,
please provide the model and serial number.**

WARNING

HIGH VOLTAGE

HV pulse amplifiers contain voltages which could be dangerous or lethal if contacted. All reasonable safety precautions have been taken in the design and manufacture of this instrument. **DO NOT** attempt to defeat the protection provided. The High Voltage Switching Modules used in the 5046E System are filled and sealed with epoxy. Any attempt to drill into or remove the epoxy will void the module and System warranty. Any unauthorized modifications or changes to any circuits in the System will void the warranty.

To minimize temperature rise within the Optical Head Assembly, the base of the OHA must be mounted and bolted onto a thermally conductive surface.

Make all electrical connections before turning power on. Check Line Voltage setting on selector located at the rear of the Power Supply/Timing Generator chassis and insure that setting is appropriate for the AC line voltage being used.

This equipment must be maintained only by qualified personnel who are familiar with high voltage components, circuits and measurement techniques. If qualified personnel are not available, the equipment should be returned to FastPulse for maintenance and repair.

Power must be removed and high voltage capacitors discharged prior to any maintenance work. Connect and disconnect all connectors only when AC line power is turned off and the power switch or AC line cord is disconnected.

Only recommended replacement parts should be used. We suggest that you contact the factory before attempting to make repairs, replacements or internal adjustments. In many instances our engineers can provide information to help diagnose a problem and suggest an appropriate solution or repair procedure.

OPERATIONAL AND CONTROL FUNCTIONS 5046ER-VC Power Supply/Timing Generator)

AC ON (Switch) Controls AC Line Voltage (ON/OFF).

AC ON (Lamp) When lighted, indicates AC Line Voltage is applied.

INPUT:-"PHOTO" (BNC) Provides for connection to an external, customer supplied PIN photo diode. Center pin of BNC provides a bias level of +12 VDC thru an internal 50 ohm termination. If the external photo diode has its own, internal bias source, use the Trigger Input connector which has a blocking capacitor (instead of the PHOTO connector). Alternatively, negative going pulses can be applied to the PHOTO connector if a blocking capacitor is used to block the internal DC bias voltage.

INPUT-TRIGGER (BNC) Provides for connection to positive polarity pulse signal sources.

INPUT-MON (BNC) Produces an output signal that allows level verification of either PHOTO or TRIGGER input source to assure signal detection is possible. When a MON output pulse is present, the triggering signals are satisfactory.

INPUT-SENS (Control) For threshold sensitivity adjustment of the PHOTO or TRIGGER inputs.

IN/OUT DELAY (Control)
Allows adjusting delay between input trigger detection and generation of an output pulse.

EXT GATE (BNC) Works in conjunction with IN/OUT DELAY. Provides connection to an external command trigger pulse that initiates extraction(s) from a mode-locked C-W pulse train. This function is not used with Q-Switched (Burst) extraction(s).
The mode locked pulse train is applied to the INPUT-TRIGGER or INPUT-PHOTO connectors.

GATE SIGNAL (Switch)
INTERNAL-EXTERNAL When switched to EXTERNAL used with CW Mode Locked Lasers for gating output pulses that are synchronized to the mode lock frequency. When switched to INTERNAL: disables EXT GATE (CW) connector; must use INPUT PHOTO or INPUT-TRIGGER connectors for slicing a pulse out of a CW laser beam or gating Q-switched laser pulses and/or Q-switched envelope.

PULSE WIDTH (Control) Allows adjusting the timing between the OFF trigger with respect to the ON trigger which corresponds to a change in Pulse Width.

MON (BNC) The Pulse Width Monitor provides a low level approximation of the output pulse width and acts as a synch pulse prior to generating the output pulse. Also verifies that mode-locked pulse detection has occurred. Note that the MON waveform is an aid for adjusting timing and pulse width. It is not an exact representation of the output HV pulse.

HV ADJUST (Control) Provides the means for externally adjusting HV DC as indicated by the meter. HV is applied to the HV Switching Modules within the Optical Head Assembly (OHA).

VC IN (BNC) For applying an external DC voltage to control the HV level. Works in conjunction with the VC-OFF-ADJ switch. When switch is in VC position, the voltage at the HV connector is controlled on the basis of 1 kV out for +0.5 volt In with a maximum input of +5 VDC.

HV (SHV) DC High Voltage output applied to the Optical Head Assembly (OHA)

High Voltage Meter: Indicates level of voltages (kV) at the HV output connector (see ¶ above)

BIAS (MHV) Provides a voltage for biasing circuits within the 8050 module. This voltage is factory set and is not field adjustable. This voltage is not related to light modulator bias..

OUTPUTS (BNC) Connects the initiating trigger pulses (produced in the 5046ER PS/TG) to the "ON" & "OFF" HV MOSFET modules within the Optical Head Assembly. "ON" corresponds to the leading edge of the HV output pulse and "OFF" to the trailing edge.

Figure 2: FRONT PANEL OF 5046ER-VC — RACK MOUNTED POWER SUPPLY /

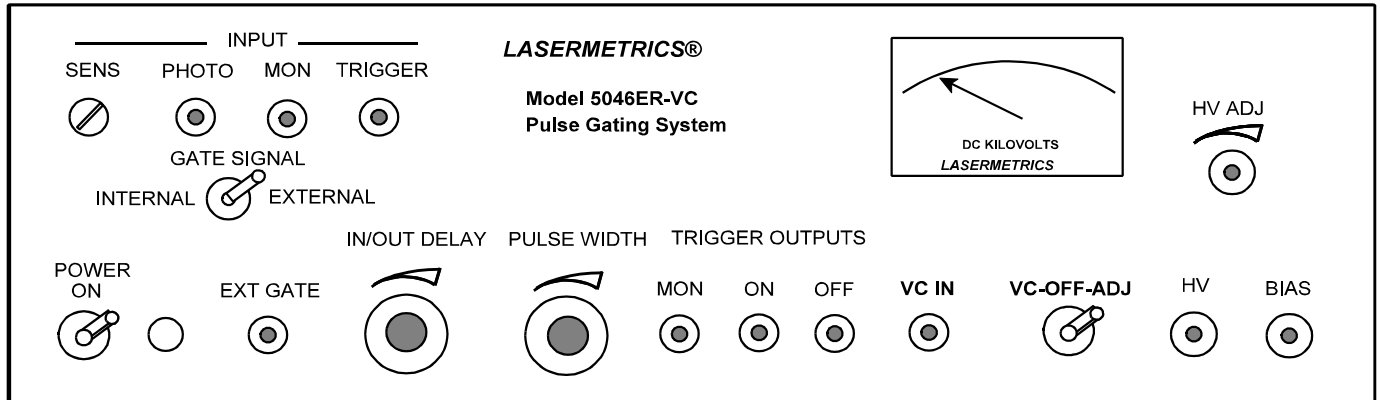

CONNECTORS

PHOTO INPUT = BNC
 MON INPUT = BNC
 TRIGGER INPUT = BNC
 EXT GATE INPUT = BNC
 MON (PULSE WIDTH) = BNC
 ON = BNC
 OFF = BNC

VC IN = BNC
 HV = SHV
 BIAS = MHV

NOT TO SCALE

GRAPHICS\5046ER-VC-FrontPanel.wpg 14 August 2013/RLG

TIMING GENERATOR: Standard 19" Width X 5.5" Height X 17.1" Deep

NOTE: A front panel switch is provided for selecting how the High Voltage is adjusted. In the center **OFF** position, power is disconnected from the HV power supply and thus the high voltage is turned off. In the **ADJ** position, HV is controlled by the front panel potentiometer knob and indicated by the HV meter. Clockwise rotation increases HV output. The minimum HV setting should be >500 Volts as indicated by the HV meter. Lower voltages may result in slow switching speeds or intermittent output voltage switching.

When the switch is set to the **VC** position, the knob/potentiometer control is disabled and has no effect on controlling HV. HV is controlled by connecting a DC voltage source to the BNC connector labeled **VC IN**. A DC voltage from ~+0.5 Volts to +5 Volts will control the HV output from ~1000 volts to ~10 kV as will be indicated on the meter. Response time of the HV power supply to changes in the **VC IN** voltage is in the range of 200 milliseconds.

5046E SYSTEM OPTICAL HEAD ASSEMBLY SHIELDED ENCLOSURES

To remove the cover from the optical head assembly, rotate the two large latch screws on top of the head 90°. The latches are open when the screw slots are orthogonal to the cover's long dimension. Carefully pull the cover off vertically. The cover is tightly fitted for electrical contact with the baseplate and endplates. The baseplate can be affixed to standard optical benches having 1 inch (2.5 cm) center to center mounting holes by means of two ¼-20 bolts (or #4 metric) on a 4 inch (100 mm) center. Bolt hole slots are located on the baseplate and are enclosed by the cover.

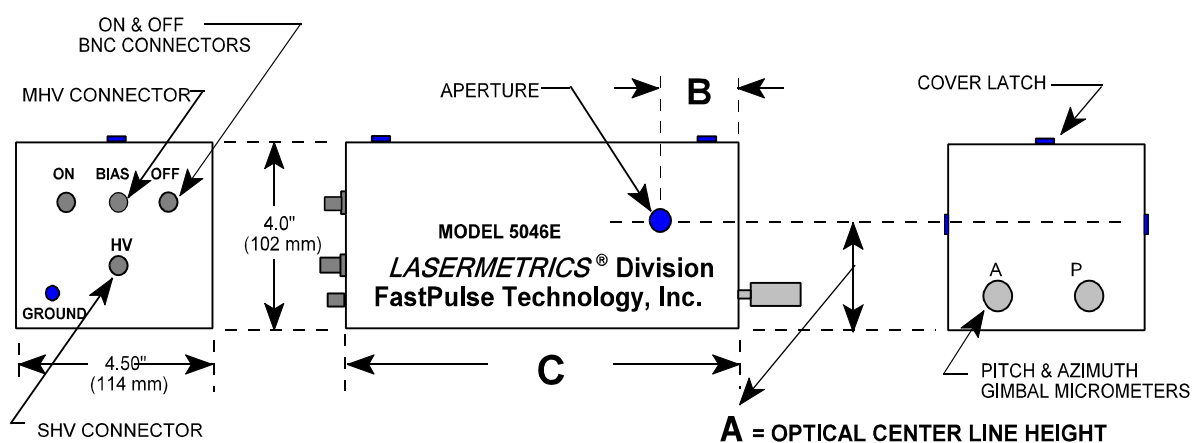

**Figure 3: OPTICAL HEAD ASSEMBLY
Models 5046E & 5046EM**

GRAPHICS\5046-OpticalHeadAssy.WPG

DIMENSION	5046E	5046EM (See Note 3)
A	2.6" (66 mm)	2.0" (50.8 mm)
B	2.4" (61 mm)	2.0" (50.8 mm)
C	9.5" (241 mm)	8.25" (210 mm)

Important Notes

1. When aligning or re-aligning the Optical Head Assembly and Pockels cell with respect to the laser beam, make certain that the beam is centered in the Pockels cell aperture. It is not sufficient to approximate the beam position in the OHA apertures. The beam must be accurately positioned at the Pockels cell apertures to prevent optical damage. We recommend that the OHA cover be temporarily removed during the alignment process. This will permit tuning for maximum extinction ratio or pulse selection amplitude while observing that the beam is centered in the Pockels cell aperture. After alignment and tweaking, power should be turned off and the cover replaced and locked before re-applying power. See additional details on Pages 16 & 17
2. The heavy aluminum base of the OHA is intended to be mounted on a thermally conductive surface to minimize temperature rise within the OHA. Two slotted bolt holes are provided to insure a good clamping action to the heat sinking surface.
3. The Model 5046EM OHA, which incorporates a Newport Model PCH-1 Gimbal, does not use micrometers for positioning. The angular adjustments are made via Hex Head screws inside the Optical Head Assembly.

1.0 GENERAL DESCRIPTION

The Model 5046ER-VC Laser Pulse Extraction & Chopping Systems are electro-optic instruments, designed to selectively gate or chop light pulses from a variety of lasers including, CW and pulse pumped conventional mode lasers and Q-switched, Q-switched / mode-locked and CW / mode-locked lasers. Extraction of a CW mode-locked pulse or a group of sequential pulses is accomplished at each command of an external signal. Pulse extracting from a Q-Switched mode-locked laser is also accommodated and can utilize the output signal of a high speed photodetector as an external command signal to initiate the timing sequences

The 5046ER-VC Pulse Extraction System incorporates a Pockels Cell light modulator and a high voltage electronic switching driver to produce nanosecond transition optical gating. The system consists of a differential FET amplifier (two Model 8050 Modules located in the Optical Head Assembly [OHA]) that is integrally mounted with a Pockels cell E-O Modulator. A remote Power Supply / Pulse Timing Generator (PS/TG Model 5046ER-VC) provides the bias and high voltages and the trigger pulse signals. The Pockels cell mounts in a two axis gimbal to provide pitch and azimuth adjustment for optical system alignment. Typically, a Glan-Taylor, air spaced calcite polarizer is used with the system to act as an output analyzer.

A simplified, equivalent circuit of the differential pulse amplifier and Pockels cell connection are shown in Figure 4. These elements are enclosed in the Optical Head Assembly. With Type I Power Supplies, $V_1 = V_2$. With Type II Power Supplies, two independent HV supplies are used to obtain special waveform effects. In Type II systems, V_1 and V_2 can be set at different values.

When the system is connected and energized, retardation voltage is applied equally to both electrodes of the Pockels cell modulator. This condition produces a zero differential voltage at the cell and thus, no optical retardation occurs.

This corresponds to minimum transmission (blocking) when the Pockels cell is located between crossed polarizers. When an input trigger pulse (from the 5046ER-VC) is applied to the 8050 Module, an ON pulse is generated which triggers the ON side (leading edge) of the differential amplifier output. Simultaneously, an adjustable, delayed trigger circuit (Pulse Width control) is activated. The OFF amplifier is controlled by this delayed trigger and remains high until the pulse width timing cycle is complete.

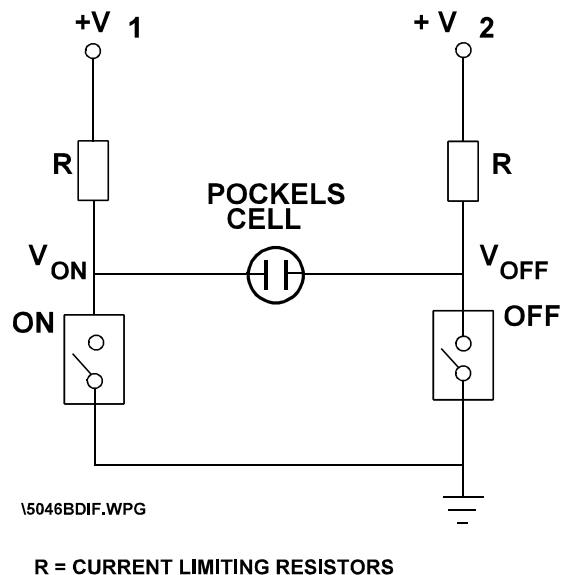

FIGURE 4: DIFFERENTIAL PULSE DRIVER

The low V_{ON} , high V_{OFF} condition produces a net differential retardation voltage across the modulator, approximately equal to the HV meter setting.

At the occurrence of the delayed trigger, the OFF amplifier is switched from its high output to a low output state resulting in a net zero differential voltage across the Pockels cell crystal; the electrically induced retardation is terminated. At this time, both amplifiers are turned off thus allowing both cell electrodes and their associated capacitance to equally recharge to the high voltage setting in preparation for the next Input pulse. Recharge time is the primary limitation on repetition rate. Typical recharge times limit maximum repetition rates for this type of circuit to ≈ 5 kHz.

1.1 System Operational Description

A photodiode detector can be utilized to sample the rejected mode-locked laser pulse train. This rejected train of pulses is present in the beam exiting the side face of a polarizer which must be located at the output side (external to the Optical Head Assembly) of the Pockels cell when the system is in a blocking state. The detected mode-locked pulses are applied to the PHOTO Input signal jack and provide synchronizing pulses to the timing logic control circuit. Note that the PHOTO input jack provides a +12 VDC voltage for reverse biasing a PIN photo detector (customer supplied.) Alternatively the mode-locked synchronizing pulses can be supplied to the TRIGGER input from an external pulse source such as the reference output of the signal generator (mode locker driver) providing mode locking reference signals.

Refer to the timing diagram, Figure 5, for two modes of pulse operation. For chopping the output of a CW laser, operation is similar except that the 5046ER-VC System will gate an optical output pulse having a width which is a function of the front panel pulse width setting.

To gate out a laser pulse from a CW mode locked pulse train (see connection diagram Figure 6), the front panel switch is set to EXTERNAL and a user provided command trigger pulse is applied to the EXT GATE BNC input jack enabling an internal logic gate. The next occurring mode-locked synchronizing pulse (applied to either the PHOTO input or TRIGGER input connectors) propagates through the enabled logic gate and triggers an adjustable time delay circuit. After the time delay, an internal trigger pulse is launched to an adjustable Pulse Width Generator that produces the ON and OFF triggers which are applied to the Model 8050 HV Switching Modules located within the Optical Head Assembly.

High voltage pulses generated by the HV Pulse Modules are applied to the Pockels cell. The resultant optical gate will allow the transmission of one or more mode-locked laser pulses. The adjustable time delay allows

centering the gate to straddle one or more mode-locked laser pulses depending on the front panel PULSE WIDTH setting.

In the case of chopping a CW beam or narrowing a Q-switched pulse, the output pulse from the 5046ER-VC System can be adjusted from less than 10 nanoseconds to about 1 microsecond in width.

Extracting a pulse from a Q-Switched mode-locked laser follows the same sequences (see connection diagram Figure 7). Selecting the "EXTERNAL" mode disables the "INTERNAL" inhibiting gate thus allowing each occurrence of a Q-Switched mode-locked pulse train to synchronize the internal timing logic. The first pulse to exceed the SENS threshold pre-set level initiates this process.

Refer to the User's guide for KD*P, RTP & Lithium Niobate Q-Switches & Modulators .at rear of this manual for additional details on the operation of the Q-switch and differential drivers.

CW MODE LOCKED LASER

GATE SIGNAL SWITCH IN "EXTERNAL" or "CW" POSITION

PULSE TRAIN (used as reference enabling signal in CW mode, applied to TRIGGER or PHOTO Input)

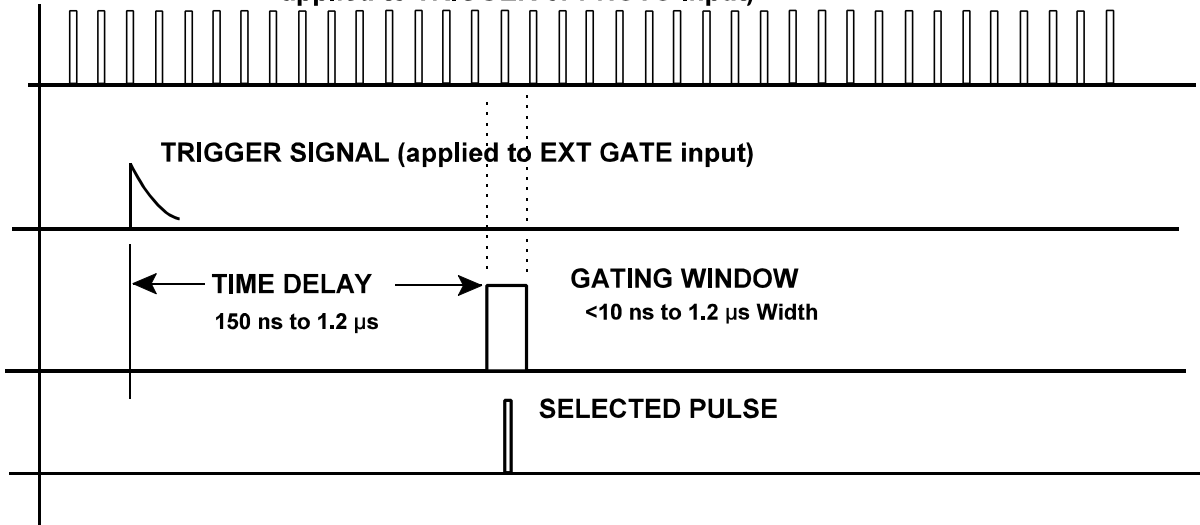

PULSED Q-SWITCHED LASER

SWITCH IN "INTERNAL" or "Q-SW" POSITION

Q-SWITCHED ENVELOPE
(not used for internal timing, for reference only)

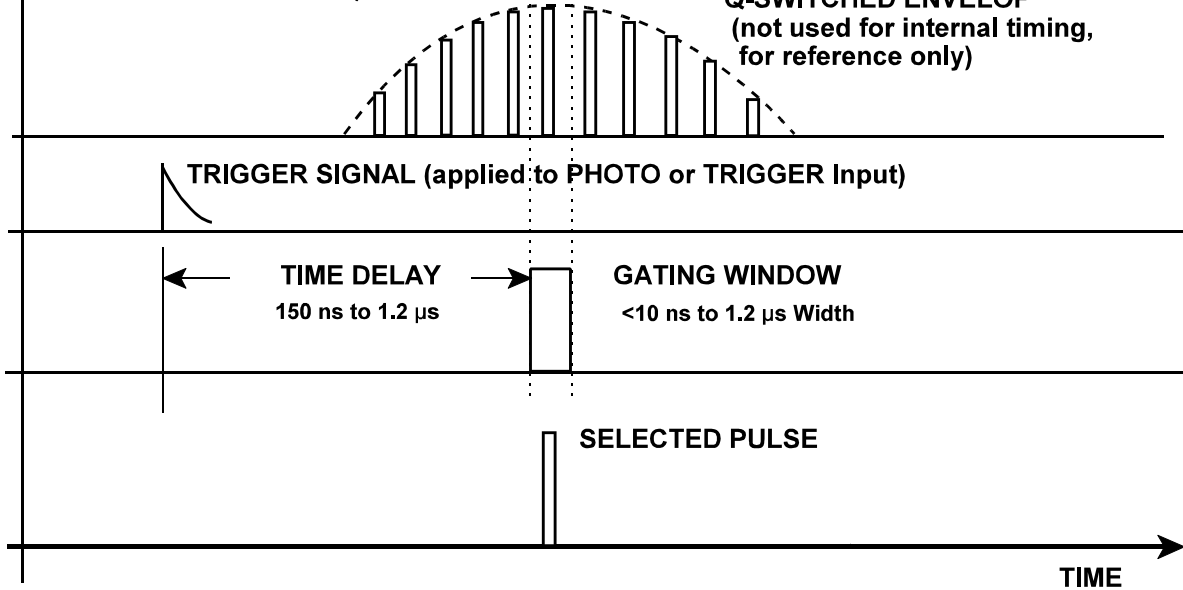

FIGURE 5: OPERATION OF 5046E AND 5046ER SYSTEMS WITH CW MODE LOCKED AND PULSED Q-SWITCHED LASERS.

2.0 OPTICAL SYSTEM - GENERAL DESCRIPTION

The active optical element of the Model 5046ER-VC System is a Pockels cell light modulator. When subjected to an electric field, the Pockels cell crystal induces a phase shift (retardation) between the ordinary and extraordinary light rays traveling through the cell. It is assumed that linearly polarized light is input to the cell or that a linear polarizer will be used at the input. The 5046ER-VC system is designed to accept a horizontally or vertically polarized beam. To operate as a shutter, an analyzer (polarizer) must be placed at the Pockels cell output and crossed to the incoming polarization direction of the laser source.

Relative phase change is a linear function of the applied voltage. When the halfwave retardation voltage is applied to the Pockels cell, an effect is produced on linearly polarized light that is similar to the effect obtained by inserting a $\frac{1}{2}$ wave optical retardation plate into the optical path. That is, a 90° rotation of the plane of polarization of the propagating light.

The value of the halfwave retardation voltage is dependent on the type of Pockels cell utilized and the operating wavelength, and is specified in the data sheet supplied with the system. The value given is a reference DC voltage level. Pulsed operation requires higher voltages and actual power supply voltage settings must be determined by observing the output optical signal. When the optical output signal pulse is maximized, the voltage across the Pockels cell is the half wave voltage.

To utilize the Pockels cell as an electrically activated shutter, a linear polarizer must be in place at the output end of the cell to act as an analyzer or polarization discriminator. Unless otherwise specified, a calcite Glan-Laser (Glan-Taylor) Q-Switch type polarizer is used. A similar polarizer is required on the input side of the Pockels cell if the incident laser beam is not linearly polarized.

2.1 Optical System Alignment

To achieve maximum modulation efficiency or extinction ratio, it is necessary that the electric vibration vector of the incident light coincide with the proper crystallographic axis or axes of the Pockels cell crystal.

The Pockels cell modulators utilized in the Model 5046ER-VC are normally aligned for a vertical and/or horizontal plane polarized input beam.

The input plane of polarization must be aligned to the X or Y axes of the modulator crystal to an angular tolerance of less than one degree.

The plane of either the X or Y crystal axis (they are interchangeable) is parallel to the plane of the electrical terminals of the modulator.

This critical alignment is necessary to realize the maximum attainable extinction ratio (contrast ratio). Further, the laser beam must transit the modulator crystal parallel to the direction of the crystal's Z (crystallographic) axis. To attain positioning accuracy in pitch and azimuth with respect to the laser beam and crystal Z axis, a precision gimbal (Model MG-145) is provided to tilt the modulator in the X and Y planes (X = azimuth, Y = pitch). To achieve proper orientation, the modulator pitch and azimuth position must be carefully tuned to obtain the best contrast ratio. Positioning accuracy to within 1 minute of arc is necessary.

As a starting point in the mechanical alignment, remove the cover from the optical head assembly after 90° rotation of two large latch screws on top of the head. The latches are open when the screw slots are orthogonal to long dimension of the cover. The head baseplate can be affixed to a mounting surface by means of two $\frac{1}{4}$ -20 bolts on a 4 inch center. Bolt holes are located on the baseplate.

Insure that the laser beam is centered in the Pockels cell aperture. The reflected image (from the Pockels cell) of the incident beam must be coincident with the laser source. A grouping of return images may exist especially when polarizing optics are integrally mounted. Continue to utilize pitch and azimuth adjustments until an intensity minimum through the complete system of polarizer, modulator and analyzer is obtained. Care must be taken to insure that the intensity minimum is not caused by vignetting at the aperture end plates. (Continued - next page)

A detailed alignment, orientation and operation guide for modulators and differential type pulse drivers is available in the User's Guide provided as a supplement to this manual.

CAUTION Misalignment of the Pockels cell with respect to the incident laser beam may cause catastrophic damage to the crystal element. Such misalignment may permit the metallic electrodes to be irradiated by a high energy or high average power optical pulse with subsequent vaporization of small areas of the electrodes. The metallic vapor deposits unevenly on the optical surfaces and can drastically reduce transmission. The deposit usually appears to radiate from the edges of the electrodes into the clear aperture. Damage can also result from irradiating the external aperture stop of the stainless steel window holders. Metallic particles can be deposited on the external surfaces of the windows. These particles act as low threshold damage sites which will burn the antireflection coatings and the fused silica window material. If a laser beam does not clear the aperture edges by at least 1 mm, and the Pockels cell must be tilted, it is recommended that an aperture stop be located between the high energy laser source and the cell to reduce beam diameter. A distance of 5 to 6 inches from the Optical Head Assembly Apertures/Pockels cell is usually reasonable. This is especially important if the diameter of the beam is nearly equal to the clear aperture of the cell.

Insure that electrical power is off and make all electrical connections before attempting to optically align the Optical Head Assembly. Alignment accuracy is critical to obtaining good performance and twisting or pushing connectors onto the assembly may cause substantial shifting of position.

3.0 SYSTEM CONNECTIONS

NOTE: Before proceeding with system connection, insure that the AC Power Switch is in the "OFF" position and that the HV and SENS Control knobs are turned full counterclockwise. Check that the AC Line Voltage selector switch is set to the appropriate line voltage setting.

3.01 Connect the "ON" and "OFF" trigger outputs of the 5046ER-VC PS/TG cabinet to the matching trigger inputs on the Optical Head Assembly (OHA). Use the 50 ohm cables (RG-58/U) with BNC connectors provided.

The left hand (facing the front panel) trigger output of the power supply cabinet is the "ON" connector and the right hand output is the "OFF" connector.

3.02 Connect the HV output, HV, on the PS/TG to the HV input on the OHA using SHV connectors and RG-59/U cables provided. For Type I systems (standard) only one HV output connector is provided on the power supply and one on the OHA. For Type 2 Systems, with two HV supplies, the designations are HV1 & HV2

3.03 Connect the low voltage control voltage source to the HV Control BNC connector. The source must be capable of provide up to 200 milliamps at the maximum input voltage of 7 Volts DC.

3.04 Connect the BIAS Output on the 5046ER-VC to the BIAS Input connector on the OHA using the MHV connectors and cable provided.

3.1 Input Functions

Two input jacks are provided to accommodate either positive or negative pulse sources. The TRIGGER jack is used for positive input signals. The PHOTO jack is used with a PIN Photo Diode where positive voltage reverse biasing is required (+12 VDC bias voltage is present at the BNC PHOTO connector). Output pulses from a positive voltage, reversed biased diode will be negative going, switching toward ground (0 volts). Negative going pulse signals may be applied directly to this input if capacitor coupling is provided (DC bias is blocked) to protect the pulse source. The positive TRIGGER jack is internally de-coupled (blocking capacitor) and positive going trigger signals with a DC level can be applied to this connector.

If externally divided CW modelocked synched pulses are available, they may be applied to the appropriate positive or negative input jack (PHOTO or TRIGGER). The divided extraction rate should not exceed the 5 kHz extraction repetition rate limits specified for the 5046. An "EXT GATE" CW command trigger input is not required and the Mode Selector switch must be set to "INTERNAL". Do not exceed the maximum extraction repetition rate indicated for the HV Output Module shown on the Specifications table. Higher repetition rates may cause overheating of resistive components resulting in premature failure.

The INPUT SENS sensitivity control, in conjunction with the INPUT MON (monitor) jack is used to verify that an input signal has sufficient level to be detected and to adjust the threshold for detection. Threshold sensitivity for either input is recorded in the specifications. Note that the indicated INPUT MON voltage level must be met or exceeded. To verify detection, slowly turn the SENS control clockwise until an output pulse is produced at the PULSE WIDTH MON connector. NOTE: To observe pulses at the PULSE WIDTH MON connector, the PULSE WIDTH control cannot be at the zero (max. counterclockwise) setting.

3.2 In / Out Delay Functions

An adjustable delay control is used to set the occurrence of the OUTPUTS output trigger pulses that produce the optical time window or pulse width. The IN / OUT DELAY adjustment range is recorded in the specifications. Final adjustments are made in conjunction with optical measurements of the laser energy waveform.

3.3 Pulse Width Generator

The Pulse Width generating process incorporates a high speed switching circuit which, when triggered, produces an output pulse whose duration can be adjusted by a front panel control. The ON and OFF output trigger pulses (derived from the Pulse Width front panel setting) are applied to the output differential amplifier in the OHA which generates high voltage pulses that are applied to the Pockels cell. This produces an optical time gate whose leading and trailing edges correspond to the leading and trailing edges of the trigger output pulses. The range of

the gate's width is recorded in the specifications. The PULSE WIDTH MON connector signal allows the user to pre-set an approximate pulse width (time difference between ON and OFF

trigger pulses) by measuring pulse duration as displayed on an oscilloscope.

The ON and OFF output trigger pulses can also be observed directly and their separation measured. Note that the output signal from the PULSE WIDTH MON connector is an approximation of the HV output pulse width since its rise and fall times may be slower than the actual HV output rise and fall times.

3.4 Unsynchronized CW Mode Operation - Relation to Jitter

For lowest jitter performance, in the range of 1 nanosecond, the TRIGGER Input and EXT GATE signals must be synchronous. When these signals are not in synchronism, jitter will increase and may become random, depending on signal characteristics. For instance:

Assume a TRIGGER input signal of 20 MHz and an EXT GATE signal of 4 kHz with a pulse width of 50 nanoseconds. With no synchronization between the two signals, the EXT GATE can be energized randomly at any time during the 20 MHz period (1/f). The repetition period of a 20 MHz signal is 50 nanoseconds. Therefore, the maximum jitter could approach 50 nanoseconds for that frequency. As frequency increases, the repetition interval (period) becomes smaller so that at 100 MHz the maximum expected jitter would be 10 nanoseconds.

For stable operation, the TRIGGER Input signal should be a positive pulse having a rise time not greater than 2 nanoseconds. A sine wave will not provide proper, jitter-free operation.

4.0 SYSTEM OPERATION

NOTE: To initially align the Pockels cell polarizer combination it is necessary to employ a photodetector with a DC response. It is recommended that alignment be performed with a low power (<5 milliwatt He-Ne laser). Focusing optics may be needed to concentrate the beam if the detector does not have high sensitivity. The focusing optics must be removed from the system when a high power laser is used. Refer to the User Guide at the rear of this manual for detailed information on alignment and cautionary practices.

4.01 Energize the 5046ER-VC PS/TG cabinet and adjust HV to the required output level. This value will generally be the half-wave voltage of the Pockels cell. Consult the Pockels cell data sheet for the DC test voltage measured at 633 nanometers. The voltage setting required to attain half wave retardation with a voltage pulse will be between 15% to 50% higher than the DC test voltage due to the lower AC electro-optic coefficient and switching circuit voltage drops. Required voltage is directly proportional to wavelength and if operation at a wavelength other than 633 nm is required, the Pulsed Output voltage will have to be adjusted accordingly by increasing or decreasing the HV level, i.e., required voltage is directly proportional to wavelength.

4.02 The null transmission level is critical in obtaining the highest possible extinction ratio. The HV setting has minimal effect on the null. Variations in null levels are usually due to slight differences in optical alignment or residual birefringence in the crystal.

4.03 To trigger the system, apply a positive voltage pulse to the TRIGGER input of the PS/TG and adjust the SENS control. Consult the "Specifications and Test Data" for positive or photo/negative input limits. Normally, +12 volt photo diode bias is present at the PHOTO input connector if needed.

4.04 To optimize optical performance of the system, view the output polarizer's transmitted laser pulse with a fast photo detector system or pulse power meter.

Adjust the DC Input control voltage (and subsequently the HV DC Output) for maximum

amplitude of the detected laser pulse. At this time, the output pulse width can also be adjusted.

4.05 Adjust the PULSE WIDTH control to produce the desired output pulse shape. This may be initially accomplished by observing the time displacement between the ON and OFF OUTPUTS pulses. The PULSE WIDTH MON output will provide a low voltage (millivolts) output that may also be used - however, remember that this MON signal is not a full representation of the HV output pulse. It is intended to show that the system has been triggered

4.06 To set the input/output propagation delay, set the DELAY control to the desired interval. See specifications for delay limits. By observing the output polarizer's rejected laser pulse, final delay adjustments can be made.

4.07 To photo trigger the unit, verify that +12 VDC diode bias is present at the PHOTO input jack. Connect the cathode terminal of a fast rise time detector to the PHOTO input connector via a 50 ohm coaxial cable such as RG-58/U. Adjust optical density filters in the photodetector to trigger on the desired light level. Or, adjust the SENS control until stable triggering occurs.

5046E CONNECTION DIAGRAM
FOR CW MODE LOCKED LASER APPLICATIONS

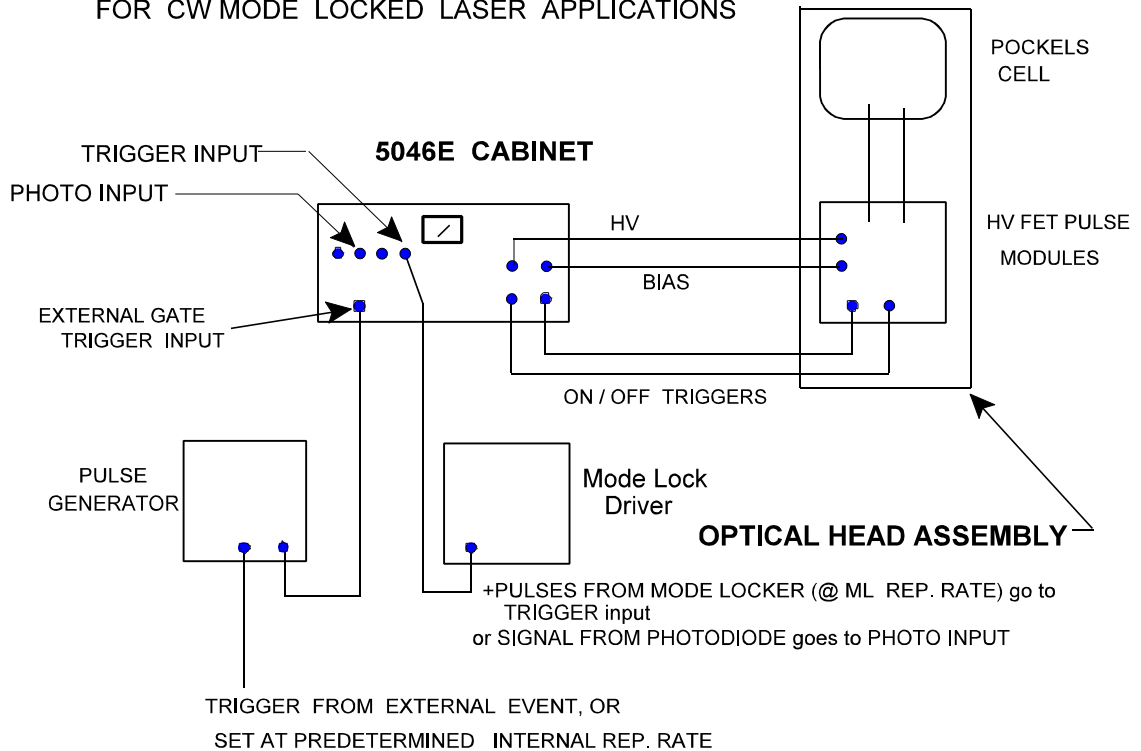

5046BLOK.WPG

Figure 6: CONNECTIONS FOR USE WITH CW MODE LOCKED LASERS

Set the front panel switch to EXTERNAL. A reference signal (positive going pulses), from the mode locker driver (monitor or reference output) is applied continuously to the TRIGGER connector. Alternatively, the PHOTO input connector may be used with a fast photodiode. A convenient +12 volt bias voltage is present at this connector for reverse biasing the photodetector. The TRIGGER and PHOTO inputs are internally connected in parallel. To use the PHOTO input with a source (negative going pulses) other than a photodiode, a blocking capacitor must be connected to prevent DC voltage from effecting the source. The TRIGGER input circuit incorporates a DC blocking capacitor and may be used with either AC or DC level pulse signals. By application of a command or gating pulse to the EXT GATE connector, obtained from a pulse generator or some external event, the internal trigger circuits are enabled. The next reference pulse generates the optical gating signal that activates the Pockels cell. The reference pulse should arrive 5 nanoseconds or more after the command trigger for proper operation.

Refer to paragraph 3.4 for CW Mode operation with unsynchronized signals.

5046E CONNECTION DIAGRAM FOR Q-SWITCHING,
Q-SWITCHED MODE LOCKED PULSE SELECTION &
PULSE CHOPPING / SLICING .

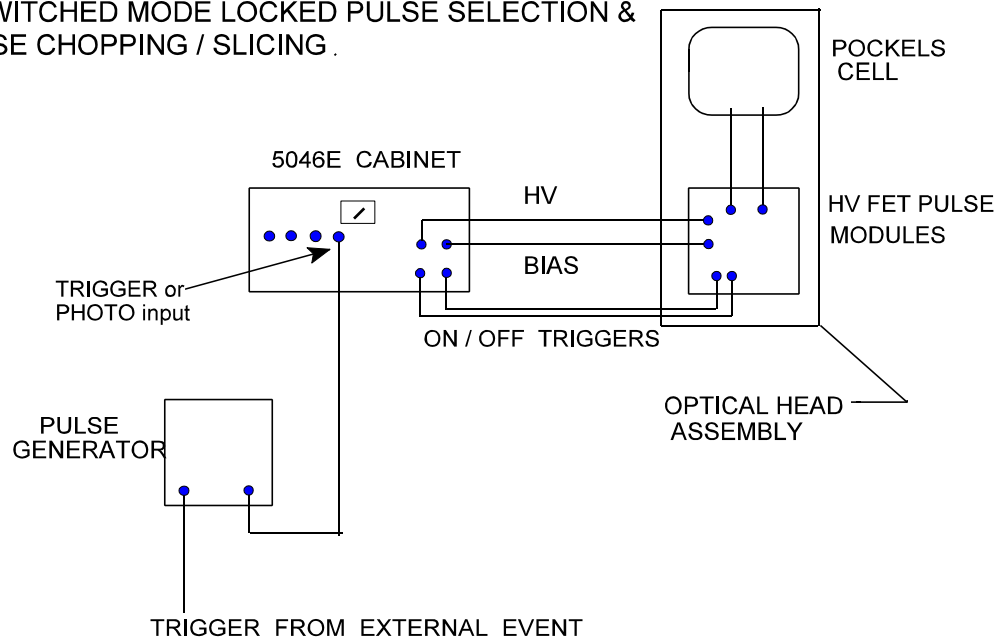

5046BLKb.VPG

Figure 7: CONNECTIONS FOR USE WITH PULSE PUMPED Q-SWITCHED, Q-SWITCHED/MODE LOCKED AND CW LASERS

For selecting a particular mode locked pulse from a Q-switched-mode locked envelope or chopping/slicing a portion of a Q-switched or a conventional laser pulse, set the front panel switch to INTERNAL. Apply positive going trigger pulses (typically derived from the Q-switch drive signal) to the TRIGGER input connector. Alternatively, trigger signals from a photodetector can be applied to the PHOTO input. This input provides a +12 volt bias for the photodetector. The PHOTO input can be also be used with other low impedance sources (pulse generator) and negative going trigger pulses provided a blocking capacitor is utilized to decouple the trigger source from the internal bias. The TRIGGER input circuit employs a blocking capacitor and either DC or AC level pulses may be applied to this input. The SENS (sensitivity) control is adjusted to set the level on the envelope at which the system will be activated. The IN/OUT DELAY sets the time delay before an output pulse (gating window) is generated by the HV Pulse Module. The SENS and IN/OUT controls can be used together to optimize the selection of a particular mode locked pulse in the envelope. The PULSE WIDTH control determines the length of the output time window, and thus either the complete Q-switched pulse and its mode locked contents or a given number of pulses may be selected.

Note that the Figure 7 configuration is also used for chopping of a CW or pulsed laser beam. Width of the gated beam is controlled by adjustment of the PULSE WIDTH control.

Refer to the Specifications Tables for input levels and ranges.

Figure 8: 5046 CONNECTION DIAGRAM FOR DIRECT TRIGGERING OF THE "ON" and "OFF" TRIGGER INPUTS

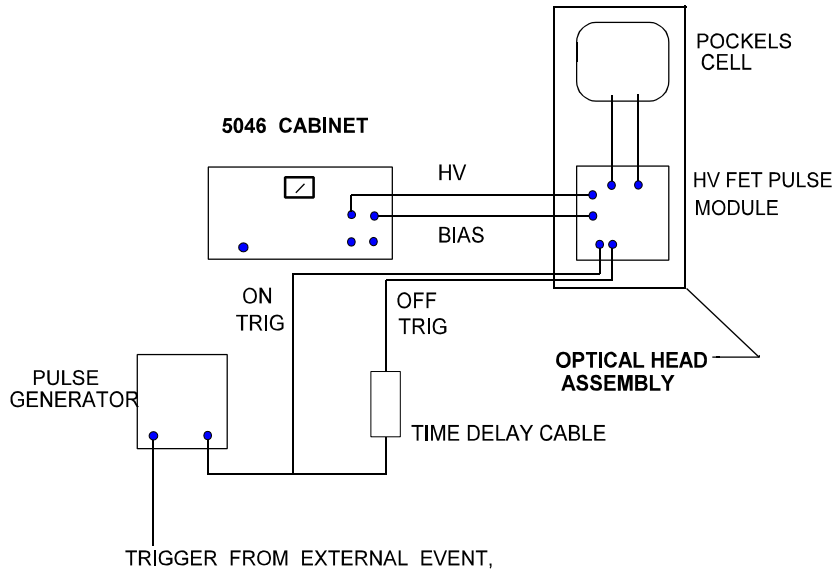

5046BLKc.WPG

5.0 DIRECT TRIGGERING OF HV MODULES (In Optical Head Assembly)

5.01 If the minimum delay introduced by the PS/TG internal timing circuits is excessive for a particular application, the HV modules within the Optical Head Assembly (OHA) may be triggered directly. To operate in this manner, it will be necessary to disconnect the "ON" & "OFF" trigger cables between the 5046ER-VC PS/TG and the OHA which contains the HV modules.

Refer to Figure 8. The ON and OFF connectors on the OHA panel are utilized, and, from an external pulse generator, apply two trigger pulses - one for the leading edge (ON) of the desired optical window, and one (OFF) for the trailing edge. For gating narrow time windows (≈ 5 to 20 ns), the "ON" trigger pulse can be delayed through a length of 50 ohm cable and applied to the "OFF" trigger input. This delay is ≈ 1.5 nanoseconds per foot of cable. Note that the ≈ 3 to 4 nanosecond rise and fall times will limit the minimum attainable pulse width. Maximum pulse width is approximately 2 microseconds.

5.02 When direct triggering of the HV Pulse Modules is used, note that the delay time between TRIGGER inputs and HV output is nominally 40 ns and is slightly dependent upon the HV operating level, trigger input level, and repetition rate. This is the propagation delay time of the internal electronic elements. Propagation delay for the modules has been minimized for the type of high voltage elements used.

6.0 EMI CONSIDERATIONS

5046ER-VC Systems utilize a shielded enclosure for the high voltage pulse modules and Pockels cell. This instrument is constructed to provide shielding of internally generated electrical noise and immunity from external noise and transients. It is essential that the instrument be correctly connected and that the AC power mains ground have a low impedance. Further, the chassis of the 5046 Power Supply / Timing Generator must be grounded (by means of the grounding terminal on the rear of the chassis) to a "house" ground. If the instrument is placed on a typical metal optical bench, a low impedance ground must be connected to the bench ground.

5046ER-VC Systems utilize a two part aluminum optical head assembly which contains the HV Modules and Pockels cell. All electrical connections are made through appropriate cables to the connectors mounted on the head assembly. All seams in this housing are closed by conductive gasketing or contact fits to prevent radiated emissions. The only openings in this assembly are the apertures through which the laser beam propagates. These apertures cannot be blocked and are thus potential sources of radiated noise (usually quite negligible).

Interconnecting coaxial cables must be matched to the impedance of the connectors used on the instrument. Thus, 50 Ω BNC connectors must be mated to 50 Ω cable and 75 Ω MHV connectors must be mated to 75 Ω cable. Severe impedance mismatches due to using improper cables will cause ringing and radiated emissions. The interconnecting cables supplied with the system are matched for proper operation.

FastPulse Technology, Inc.

LASERMETRICS® Division

220 MIDLAND AVENUE
SADDLE BROOK, NEW JERSEY 07663
TEL (973) 478-5757
FAX (973)-478-6115
WebSite: fastpulse.com

WARRANTY

Each standard component and instrument manufactured by FastPulse Technology and/or its **LASERMETRICS®** Division is guaranteed to be free from defects in material and workmanship for a period of one (1) year from the date of shipment to the original purchaser. This warranty does not apply to non-standard equipment or equipment modified to meet customer special requirements. For modified or specially produced instruments the warranty period shall not exceed 90 days after date of invoice. All warranties are voided if any instrument or equipment is operated improperly or beyond its safe operation limits; without proper routine maintenance, or under unclean conditions so as to cause optical or other damage; or if it is otherwise abused, connected incorrectly electrically, exposed to power line or other electrical surges, or modified in any way.

Our liability under this warranty is restricted to, at FastPulse Technology's option, replacing, servicing or adjusting any instrument returned to the factory for that purpose, and to replacing any defective parts. Specifically excluded from any warranty liability are indicator lamps; vacuum, gas and vapor tubes; fuses, batteries, optical coatings, components in lasers and laser systems such as: focusing lenses and other optical components internal or external to the laser cavity, expendable items such as flash lamps, water filters and the like. FastPulse Technology does not assume liability for installation, patent violation claims, labor, injuries, or consequential damages.

Equipment under warranty must be returned to the factory with transportation charges prepaid and with advance notice to FastPulse Technology. Repaired equipment will be returned to the purchaser with shipping charges prepaid. If it is deemed impractical to return the equipment to the factory, the purchaser may request the dispatch of a FastPulse Technology service engineer whose services, travel and living expenses will be charged to the purchaser at the then current rates.

In many instances, equipment problems can, with the purchaser's assistance, be resolved through brief communications with a factory engineer either by telephone, FAX or e-mail. Should, in FastPulse Technology's opinion, the problem be caused by a component or subassembly failure, the Company shall at its discretion ship a replacement to the user, and/or request that the failed component or subassembly be returned to the factory for analysis or repair.

This warranty does not imply and is expressly in lieu of all other liabilities, obligations, or warranties. FastPulse Technology neither assumes nor authorizes any other person or organization to assume on behalf of FastPulse Technology any other liability in connection with these products. FastPulse Technology disclaims the implied warranties of merchantability and fitness of such products for a particular purpose. It is the purchaser's responsibility to insure that the products are suitable for the purchaser's application.

CLAIM FOR DAMAGE IN SHIPMENT

The equipment must be tested within 10 days after receipt. If it fails to operate properly, FastPulse Technology, Inc. must be promptly notified. If there is external damage to the packaging or there is internal damage, a claim must be filed with the carrier. A full report of the damage should be obtained by the claim agent and this report should be forwarded to FastPulse Technology. We will then advise the disposition to be made of the equipment and arrange for repair or replacement.

Include model number and serial number when referring to this equipment for any reason

Addendum to USER GUIDE for the 5046ER-VC

Changing AC Line Voltage Connections - Rack Mounted Configuration ONLY

The 5046ER-VC Rack Mounted version of the 5046E incorporates a special AC Power Line Voltage Selector and EMI Filter Assembly which is located on the rear of the chassis. The Assembly permits changing the AC line voltage settings at which the 5046ER-VC will operate. The available positions are: 100 Volts, 120 Volts, 230 Volts and 240 Volts.

The procedure for changing to any other settings is as follows:

1. Disconnect the AC line voltage by pulling the plug from the wall socket and also remove the plug from the rear of the chassis.
2. In the rear of the rack unit chassis there is a black AC line cord socket assembly. Refer to figure below. The left side has a socket and on the other side has a plastic cover that can be opened with a knife point or screwdriver. On one side of this cover, a small white plastic point protrudes out of one of four (4) holes. Each hole has a voltage marking (100 V, 120 V, 230 V, 240 V).*
3. To change the voltage setting to 100 V, pry the cover off. This will expose a white plastic part (with the point) attached to a tiny printed circuit board. Pull the board out of its socket. Note that the plastic part can be repositioned on the board by sliding it in the slotted areas and around the edge of the board.
4. To select 100 V, the PC board must be rotated until the side marked "100" and its associated arrow are on the side opposite the plastic piece. The PC board is then plugged back into the socket - with the 100 V side going in first. Note that the white plastic piece has an arrow head that points to small arrow heads on the black socket assembly. The arrow head points must face each other when the pieces are mated.
5. When the cover (the one that was removed) is put back on, note that the white point will now stick out of the hole next to "100 V". The AC Line socket is now set for 100 Volts AC operation. This is the MAXIMUM AC RMS line voltage that should be used. If the AC plug is thereafter connected to 120 Volts or 240 Volts, the internal circuits may be damaged.

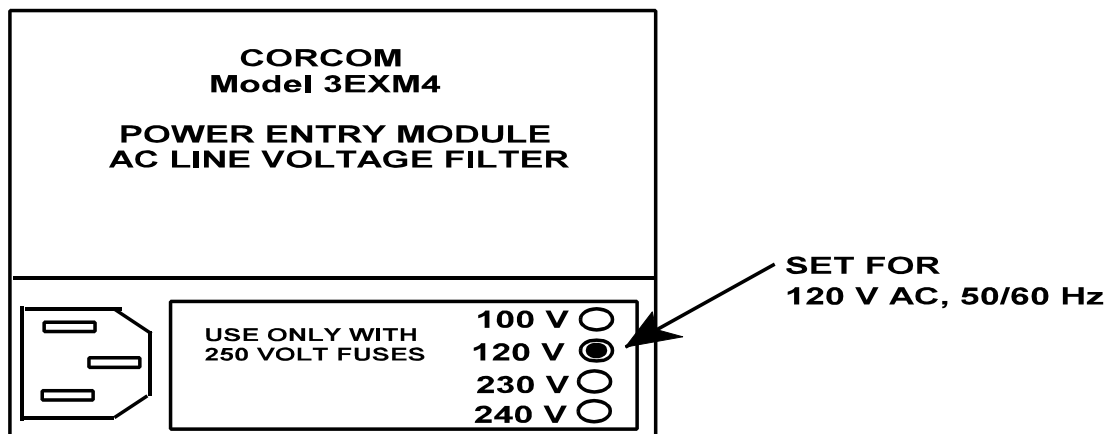

AC LINE FILTER USED IN RACK MOUNTED 5046ER SYSTEMS

MANUALS\5046ER-VC-ACline.wpd